

# CleanAir BASIC

BASIC is a mobile filtering and ventilation device, designed for workshop works on the sites contaminated with heterogeneous dusts. This unit is used at the processes of welding, grinding, pouring and wherever the dusts are generated (also adhesive, moisture or greasy ones). CleanAir Basic is adapted for cooperating with one standing extraction arm with diameter of 160 mm and range up to 2 m. The main filter element is capacity filter cartridge. The device contains also metal pre-filter and final filter of carbon impregnated fabric.

The device controller informs the user on the necessity of the filter element replacement. CleanAir Basic is powered from the 230V mains and it does not require compressed air for the operation.

## Used in processes such as:

- ▶ thermal and mechanical cutting
- ▶ welding
- ▶ grinding
- ▶ polishing
- ▶ pouring
- ▶ processing of plastics
- ▶ other bothersome industrial processes requiring air purification



### low energy consumption

- fan with capacity 0,55 kW / 230V



### three stage filtration

- metal filter
- cartridge filter
- progressive carbon filter



### occupational safety and health

- air filtration 99,9%
- low sound level



### ergonomics

- modular construction
- easy assembly and connection
- arm with diameter of 160 mm and range of 2 m
- mobile devices – wheels with diameter of 75 mm and brakes



### note

- the devices must not be used for the filtration of chemically aggressive or explosive compounds.
- max. temperature of supplied air must not exceed 60°C.
- the device may only be applied indoors.



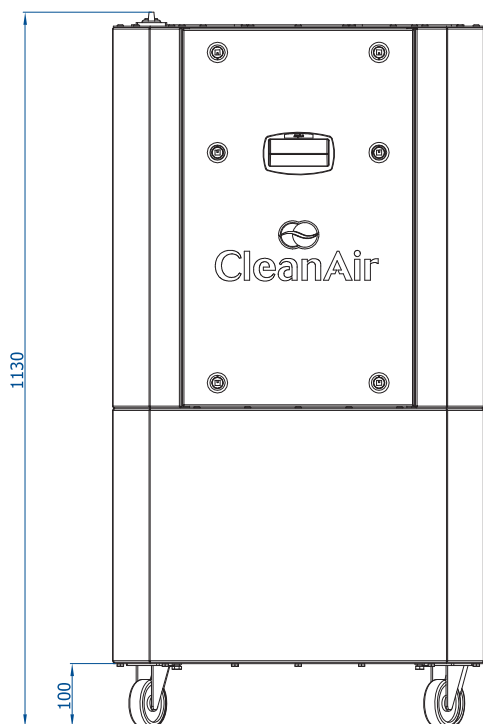
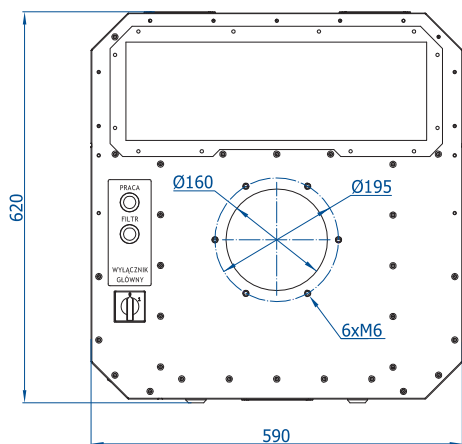

### Performance curves

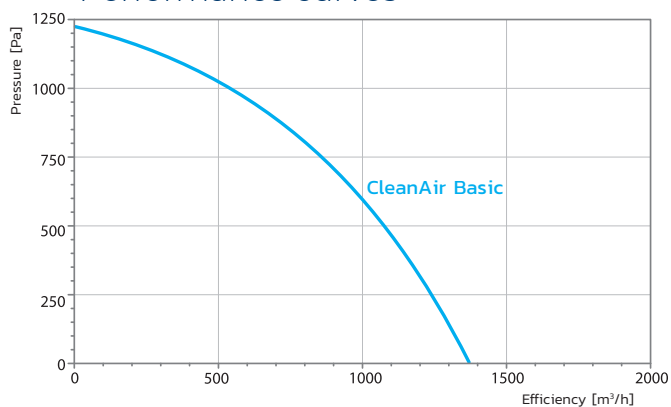

### Accessories / consumables



### Technical specifications

MODEL	BASIC
Catalog number	CAB05501
Power [kW]	0,55
Voltage [V]	230
Noise [dB(A)] - 1m	69
Volume flow [m³/h]	1400
Pressure [Pa]	1200
Weight [kg]	72

CleanAir Sp. z o.o.

Adm. A. Karwety Street 25 • 80-297 Miszewko • Poland  
☎ +48 58 629 03 36 • e-mail: biuro@cleanairfactory.pl